



# Notice of Race

## 48<sup>th</sup> NS14 Australian Championship



**Organising Authority**  
**NS14 Association of Tasmania & Midway Point Yacht Club**

**2 – 7 January 2017**

### 1. **VENUE**

The regatta will be conducted at Midway Point Yacht Club at Midway Point, Tasmania, Australia

### 2. **RULES**

The Championship will be governed by the rules as defined by The Racing Rules of Sailing for 2013 – 2016 (RRS).

### 3. **ADVERTISING**

All boats may be required to display sponsors' advertising and/or bow numbers. If required they will be provided by the Organising Authority.

### 4. **ELIGIBILITY AND ENTRY**

- a) Entry is open to all Boats Registered with the NS14 Association of their State.
- b) No entry will be accepted, and no boat will score points, unless:
  - I. the boat is sailed by a crew of two persons, both people being financial members of a club affiliated with Australian Sailing or any of its members for the 2016/2017 season;
  - II. at least one member of the crew is a financial member of a State or Territory NS14 Association, approved by the Committee of the NS14 Association of Tasmania, for the 2016/2017 season; and,
  - III. the remaining crew, if not a member as defined in 4.1 b) above and if approved by the Committee of the NS14 Association of Tasmania, agrees to become an associate member of the association for this regatta.
  - IV. Crews, who must fulfil the requirements of 4.1 b) or 4.1 c) above, may only be substituted with the written approval of the Race Committee.
- c) A completed Entry Form, shall be lodged with the Association Treasurer by 1 December 2016  
**Post: NS14 Association of Tasmania**  
**102 Branscombe Road Claremont, Tasmania**  
**Payment by either:**
  - EFT Electronic Funds Transfer or
  - Cheque made payable to the NS14 Association of Tasmania
- d) Entry fee is \$270.00 which includes

- i. 2 tickets to the Welcome Dinner and
  - ii. 2 Tickets to the Trophy Presentation
- e) Late entries may be accepted up until 2 January 2017 accompanied by an entry fee of \$300 which includes an additional late fee of \$30. Tickets to the Trophy Presentation *may* not be available for late entries.

## **5. SCHEDULE OF EVENTS**

- a) All competitors shall complete entry, registration and measurement at Midway Point Yacht Club between 1200hrs and 1730hrs on 2 January 2017.
- b) No more than four (4) races will be sailed on any one day.
- c) Race Sessions will be held as follows.

|                          |                            |                     |
|--------------------------|----------------------------|---------------------|
| Monday 2 January 2017    | Registration & Measurement | 1200hrs -> 1730 hrs |
|                          | Welcome Function           | 1800hrs             |
| Tuesday 3 January 2017   | Information Session        | 1230hrs             |
|                          | Race Session               | 1430hrs             |
| Wednesday 4 January 2017 | Race Session               | 1330hrs             |
| Thursday 5 January 2017  | Race Session               | 1330hrs             |
| Friday 6 January 2017    | Race Session               | 1330hrs             |
| Saturday 7 January 2017  | Race Session               | 1000hrs             |
|                          | Presentation               | 1800 hrs            |

- d) No warning signal will be made later than 1500hrs on Saturday 7 January 2017
- e) Additional sessions may be added by the Race Officer no later than 1 hour after the conclusion of sailing on the previous day.

## **6. EQUIPMENT AND MEASUREMENT**

- a) Only one set of spars and foils can be declared for use in the championship.
- b) 2 Jibs and 1 Mainsail can be declared for use in the championship.
- c) Measurement forms for all declared sails and spars must be in the hands of the state measurer by close of registration.
- d) All boats must conform to the NS14 class rules.
- e) Replacement of individual sails, spars and foils which are damaged after registration may be permitted only with the written approval of the race committee.
- f) Competing boats shall be available for inspection or measurement by the Tasmanian Measurer or his representative at any time during the championship

## **7. SAILING INSTRUCTIONS**

The Sailing Instructions will be available at Registration on the 2 January 2017

## **8. COURSES**

The course to be sailed by the Championship Fleet is detailed in Attachment 1. The course to be sailed by the Silver Fleet is also detailed in Attachment 1 less the second triangle. Both Fleets will use the same marker buoys and start together.

## 9. **SCORING**

- a) The Regatta will consist of ten (10) races for the championship of which four (4) races are required to be completed to constitute a series
- b) When four (4) or fewer races have been completed, a boat's series score will be the total of her race scores.
- c) When from five (5) to Seven (7) races have been completed, a boat's series score will be the total of her race scores excluding her worst score.
- d) When from race eight (8) onwards have been completed, a boat's series score will be the total of her race scores excluding her two worst scores.
- e) Handicap scoring will be maintained for the Championship.

## 10. **PRIZES**

- a) Prizes will be presented Presentation Dinner on the evening of 7 January. Prizes to be awarded include:
- b) Open Championship - (1st, 2nd & 3rd overall on scratch)
- c) Female Champion Skipper - (first female skipper on scratch)
- d) Handicap Championship
- e) Silver Fleet Champion
- f) Other prizes at the discretion of the organising authority

## 11. **INSURANCE**

Each participating boat shall be insured with valid third party liability insurance with a minimum cover of \$10,000,000. *Details of this cover must be provided with the Entry Form.*

## 12. **DISCLAIMER OF LIABILITY**

- a) It is the competitor's decision to enter the Regatta or to start in any race. Competitors shall accept their participation in the Regatta is at their sole exclusive risk in every respect.
- b) By way of entry to the Regatta competitors shall indemnify the organising authority their officers, members, servants and agents in respect of all claims and demands of whatever nature which may be made upon them in connection with or who se ever arising from their participation or intended participation in the Regatta

## 13. **AMENDMENTS**

Any amendments to this Notice of Race shall be posted on the [www.ns14.org](http://www.ns14.org) and the Midway Point YC websites no later than the 20<sup>th</sup> November 2016

## 14. **FURTHER INFORMATION**

For further information please the Midway Point Sailing Club or NS14 Association of Tasmania.

Websites [www.midwaypointyachtclub.yachting.org.au](http://www.midwaypointyachtclub.yachting.org.au)

1. [www.ns14.org](http://www.ns14.org)

# Windward-Leeward-Triangle

Attachment 1

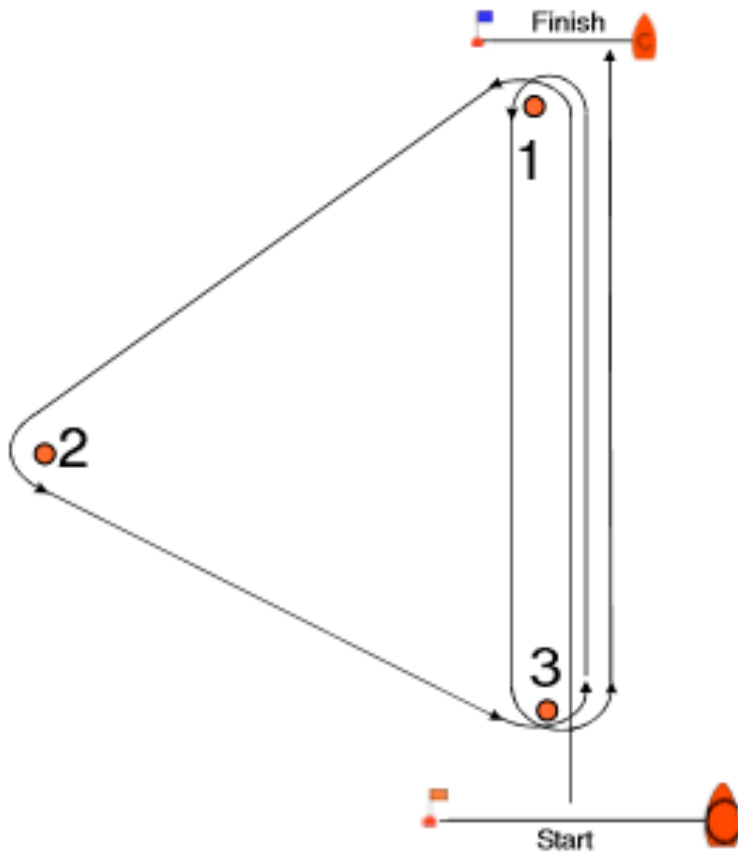

**Championship Fleet - Start 1-2-3-1-3-1-2-3-Finish**

**Silver Fleet - Start 1-2-3-1-3-Finish**

**2<sup>nd</sup> to 7<sup>th</sup> January 2017**  
**Midway Point Yacht Club**

**Entry Form**

Boat Name \_\_\_\_\_ Boat Number \_\_\_\_\_

Insurance Company \_\_\_\_\_ Policy No. \_\_\_\_\_

Select Fleet - please circle one:      **Championship Fleet**              **Silver Fleet**

Nominated sails declared for use in the Championship, Date and Size

Mainsail \_\_\_\_\_ Jib 1 \_\_\_\_\_

Jib 2 \_\_\_\_\_

Skipper \_\_\_\_\_ YA Number \_\_\_\_\_

Registered Home Club \_\_\_\_\_

Address \_\_\_\_\_ Date of Birth \_\_\_\_\_

Email \_\_\_\_\_

Mobile Phone: \_\_\_\_\_ Phone \_\_\_\_\_

Crew \_\_\_\_\_ YA Number \_\_\_\_\_

Registered Home Club \_\_\_\_\_

Address \_\_\_\_\_ Date of Birth \_\_\_\_\_

Email Address: \_\_\_\_\_

Mobile Phone: \_\_\_\_\_ Phone \_\_\_\_\_

*We hereby release the NS14 Association of Tasmania., Midway Point Yacht Club, Yachting Australia, Yachting Tas and any representative thereof, from any claim or demand that we may have or deem to have, on our behalf arising out of any loss or injury that may occur, on or arising out of the NS14 Australian Championship 2017. We indemnify the NS14 Association of Tasmania., Midway Point Yacht Club, Yachting Australia, Yachting Tas and any representative thereof against any claim that may be made. We also have third party insurance cover of not less than \$10 million for any accident. We agree to be bound by the racing rules of sailing and by all other rules that govern this Championship.*

Skipper Signature: \_\_\_\_\_

Crew Signature: \_\_\_\_\_

*If the skipper and/or crew are under the age of 18 years at the time of the NS14 Australian Championship 2017, a parent or guardian must sign this entry form on behalf of the underage participant(s).*

Signed: (Parent/Guardian of Skipper): \_\_\_\_\_

Signed: (Parent/Guardian of Crew): \_\_\_\_\_

**The entry fee includes 2 tickets to Presentation Dinner and 2 tickets to Opening Dinner.**

Extra Tickets for Opening dinner at the club, 2<sup>nd</sup> January 2017. \$20 (Child under 13: \$10)

Adult: \_\_\_\_\_ Children: \_\_\_\_\_

Extra Tickets for Trophy Dinner at the Tasmania Golf Club. 7<sup>th</sup> January 2017. Adult: \$50 Children's Menu: \$25

Adult: \_\_\_\_\_ Children: \_\_\_\_\_

Extra Tickets will be available at the Club on registration day.

**Championship Polo Tops. (High Quality Razor Polo Tops) \$35 each.**

Skipper Size: \_\_\_\_\_ Crew Size: \_\_\_\_\_

Cheer Squad Size: \_\_\_\_\_

|                                      |                     |          |
|--------------------------------------|---------------------|----------|
| <b>Entry Fee:</b>                    |                     | \$270    |
| <b>Extra Opening Dinner Tickets:</b> |                     | \$ _____ |
| <b>Extra Trophy Dinner Tickets:</b>  |                     | \$ _____ |
| <b>T-Shirts:</b>                     | <b>Number</b> _____ | \$ _____ |
|                                      | <b>TOTAL:</b>       | \$ _____ |

All entries must be completed on the prescribed NS14 Association form and **emailed** to the Treasurer:

[smwilkie70@tpg.com.au](mailto:smwilkie70@tpg.com.au)

Entry Fee is payable by Electronic Transfer using **Surname and Sail Number as the reference** to:  
**NS14 Assn of Tasmania**

**BSB: 807009**

**Acct No: 60167468**

Please confirm payment by an email to the Treasurer stating Surname, sail number and amount paid.

If electronic transfer is not able to be completed, a Cheque made payable to:  
NS14 Association of Tasmania, and attached to your entry form, can be sent to:

The Treasurer  
Scott Wilkie  
102 Branscombe Road,  
Claremont TAS 7011

**Entries Close 1st December 2017**

Late entries may be accepted with a late fee of \$30.00