

NOTICE OF RACE

NS14 New South Wales State Championship 2009 - 2010

2nd April 2010 – 5th April 2010

Gosford Sailing Club

1 VENUE & ORGANISING AUTHORITY

The Organising Authority is NS14 Association of NSW in conjunction with the Gosford Sailing Club (GSC), which is located at Masons Parade, Gosford, New South Wales 2250.

2 RULES

The Championship will be governed by the rules as defined by The Racing Rules of Sailing (RRS) and the NS14 Class Rules.

3 ADVERTISING

Advertising will be restricted to Category A.

Competitors may be required to display Event sponsor's name(s)/logo(s). If required, the Organising Authority will supply these items and they shall be affixed and/or worn as prescribed in the Sailing Instructions.

4 ELIGIBILITY AND ENTRY

4.1 No boat may score points unless:

- a) the boat is sailed by a crew of two persons, both people being financial members of a club recognised by Yachting Australia or any of its members for the 2009/2010 season
- b) at least one member of the crew is a financial member of a State or Territory NS14 Association for the 2009/2010 season; and
- c) the remaining crew is an honorary member of their relevant State or Territory NS14 Association for the 2009/2010 season.

4.2 Entries must be completed on the prescribed entry form, accompanied by the prescribed entry fee and either forwarded to the Assistant Race Secretary at the address below or emailed with direct deposit as per details below no later than 28th March 2010.

Assistant Race Secretary NS14 Association of NSW Inc. PO Box R278 ROYAL EXCHANGE NSW 1225	Email entry form to melanie.hasko@tribecaip.com.au
	Bank entry fee to: NS14 Association of NSW Inc. BSB# 112-879 Acct# 039588892 St George Bank <i>Put your boat number in the reference field</i>

4.3 Entries received after 28th March 2010 should be made by cheque or cash at registration. Late entries will not be accepted after close of registration on 2nd April 2010.

5 FEES

The entry fee for the Championship is \$130. This fee includes two (2) FREE regatta shirts, welcome drinks post racing on Friday and a DISCOUNT on tickets to the Regatta Dinner on Saturday evening.

Late entries will be accepted up until the close of registration but entries received after 28th March will not receive any free shirts or discount dinner tickets. Cheques should be made payable to the NS14 Association of NSW Inc.

6 SCHEDULE OF EVENTS

6.1 Registration

Entrants must register with the Race Secretary at Race Headquarters on Friday 2nd April 2010 between 0930 and 1200 hours. Skipper and crew must attend registration. Sails and foils declared for use in the Championship must be brought to registration for stamping. All entrants must complete a safety checklist at registration. All boats may be weighed at time of registration.

6.2 Entrants' Briefings

A Championship briefing will be held at 1230 hours on Friday 2nd April 2010 at race headquarters.

Skipper and crew are required to attend this briefing.

Further briefings may be held each day of racing at 0900 hours. All briefings will be held at race headquarters.

6.3 Race Programme

Date	Heat	First Signal
Friday, 2 April 2010	Heat 1	1425 hrs
Saturday, 3 April 2010	Heat 2	1055 hrs
Saturday, 3 April 2010	Heat 3	1425 hrs
Sunday, 4 April 2010	Heat 4	1055 hrs
Sunday, 4 April 2010	Heat 5	1425hrs
Monday, 5 April 2010	Heat 6	1055 hrs

Resails will be scheduled at the discretion of the Race Committee. If a heat is abandoned, it may be rescheduled as a heat to be sailed back to back following a programmed heat.

6.4 Social

A casual welcome evening will be held post race upstairs at GSC on Friday 2nd April 2010 at GSC.

A social dinner will be held on Saturday 3rd April 2010 at GSC. Tickets must be prepaid and remitted with the competitor entry form. Tickets will be issued at registration. Ticket costs are Adults \$25.00, Children (under 12) \$12.00. Ticket price includes a three course a la carte dinner and tea and coffee. A presentation of trophies for the Travelers Trophy, Metropolitan Trophy, Sprint Series and Three Rivers Championship will be held at this dinner.

6.5 Annual General Meeting

The Annual General Meeting of the NS14 Association of NSW Inc. will be held at GSC in the Juniors Room as soon as possible after racing on 4th April 2010. All sailors are requested to attend this meeting.

7 EQUIPMENT AND MEASUREMENT

Only one set of spars and foils can be declared for use in the Championship. 2 jibs and 1 mainsail can be declared for use in the Championship. Measurement forms for all declared sails and spars must be in the hands of the appropriate State or Territory Association Measurer by the close of registration.

All boats must conform to the NS14 class rules and shall have a valid class measurement certificate to be eligible to score points in the Championship.

Replacement of individual sails, spars and foils which are damaged may be permitted only with the written approval of the Race Committee.

Competing boats shall be available for inspection or measurement by the NSW Measurer or his representative at any time during the Championship. Boats may be weighed.

8 SAILING INSTRUCTIONS

Sailing Instructions will be available at race headquarters from 0930 hours on Friday 2nd April 2010.

9 VENUE

The primary racing area will be the waters of Brisbane Water. The approximate racing area is illustrated in Figure 1.

The rigging area is the grass area to the south of the club and surrounding the public car park. Race headquarters will be at the GSC. Boats can be stored overnight on the grass area close to the club on Friday, Saturday and Sunday nights. GSC and its surrounds are patrolled by a security organisation but GSC accepts no direct responsibility for boats stored overnight.

10 COURSES

The course to be sailed is detailed in Figure 2.

The target race time for the long course for the first boat to finish will be approximately one (1) hour and 45 minutes. The target race time for the short course for the first boat to finish will be approximately one (1) hour. Back to back racing may be short course racing at the discretion of the Race Committee.

11 SCORING

11.1 Four (4) races are required to be completed to constitute a series.

If only four (4) races are completed, each boat's series score shall be the total of her races scores without discard. If five (5) or six (6) races are completed her worst single score will be discarded.

11.2 Handicap scoring will be maintained for the Championship. The first 3 races, or a number to be determined by the Race Committee, will be used to calculate each boat's handicap to be used throughout the Championship.

12 SAFETY REGULATIONS

The attention of all entrants is drawn to Yachting Australia Special Regulations Part 2 which shall apply.

13 PRIZES

A Presentation of Trophies will be held at the GSC at the conclusion on racing on 5th April 2010.
Prizes to be awarded as follows:

1st, 2nd & 3rd Place Scratch*

1st, 2nd & 3rd Place Handicap

Female Skipper* (best female skipper on scratch)

Junior Skipper* (best skipper aged under 19 years on scratch)

Classic Division (Aero 8 or equivalent and prior) - 1st, 2nd & 3rd on scratch

Further scratch and handicap prizes may be issued, dependent on the number of entrants in the Championship.

Category prizes include:

50th Percentile

Heavyweight (Combined crew weight of over 140kgs)

Jack & Jill (male/female crew)

Veteran Skipper (aged over 50 years)

Family Crew

Husband & Wife Crew

*Scratch prize winners will not be eligible for *Handicap* or *Category* prizes.

** Female Skipper and Junior Skipper are also eligible for overall *Scratch* prizes

14 INSURANCE

Each participating boat shall be insured with a valid third-party liability insurance cover of not less than \$10 million per event or equivalent. All owners/entrants who sign the entry form are deemed to have made a declaration that they hold such cover.

15 DISCLAIMER OF LIABILITY

Competitors participate in the regatta entirely at their own risk. See rule 4, Decision to Race. The organising authority and the NS14 Association of NSW Inc. will not accept any liability for material damage or personal injury or death sustained in conjunction with or prior to, during, or after the regatta.

16 FURTHER INFORMATION

For further information, please email melanie.hasko@tribecaip.com.au

17 ACCOMMODATION SUGGESTIONS

La Salle Youth Camp

Mackillop Road Kincumber South

We have booked this facility for the Easter weekend. It offers a range of fairly basic accommodation at a very reasonable price to community and sporting organisation. Further details at www.NS14.org.

Camping & Cabins

Ocean Beach Holiday Park
Sydney Avenue, Umina Beach NSW 2250

T: 02 4379 9444

Reservations: 1800 611 522

www.oceanbeachholidaypark.com.au

(15kms from Gosford Sailing Club)

Hotel & Motels

The Galaxy Motel ★★★½
26 Central Coast Hwy, Gosford West NSW 2250

T: 02 4323 1711

www.galaxymotel.com.au

(1kms from Gosford Sailing Club)

Best Western Gosford Motor Inn ★★★
23 Central Coast Hwy, Gosford West NSW 2250

T: 02 4323 1333

www.gosfordmotorinn.com.au

(1.5kms from Gosford Sailing Club)

The Bayview Hotel/Motel ★★★½
2 The Boulevard, Woy Woy NSW

T: 02 4341 2088

www.bayview-woywoy.com

(11kms from Gosford Sailing Club)

Resort

Mantra Ettalong Beach ★★★★★
53-54 The Esplanade, Ettalong Beach NSW 2257

T: 02 4344 8888

www.mantraettalongbeach.com.au

(15kms from Gosford Sailing Club)

FIGURE 1

Approximate Racing Area Indicated by 

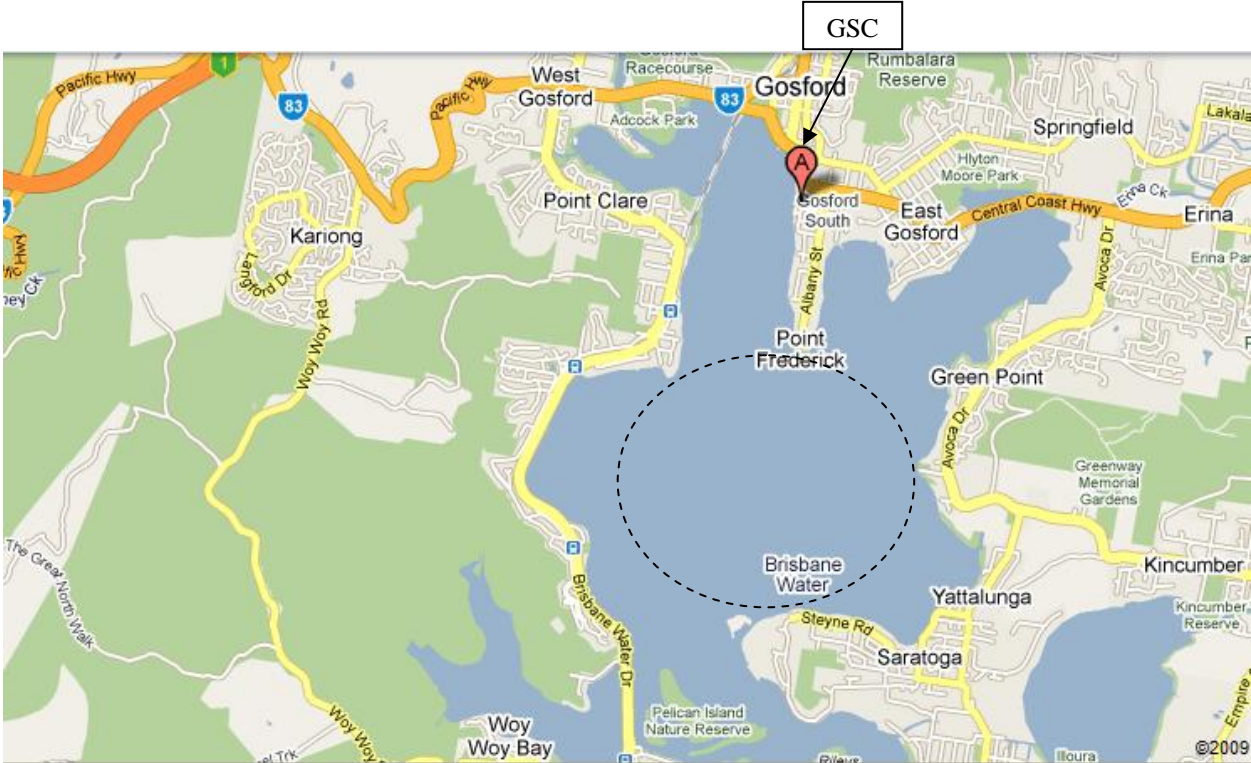
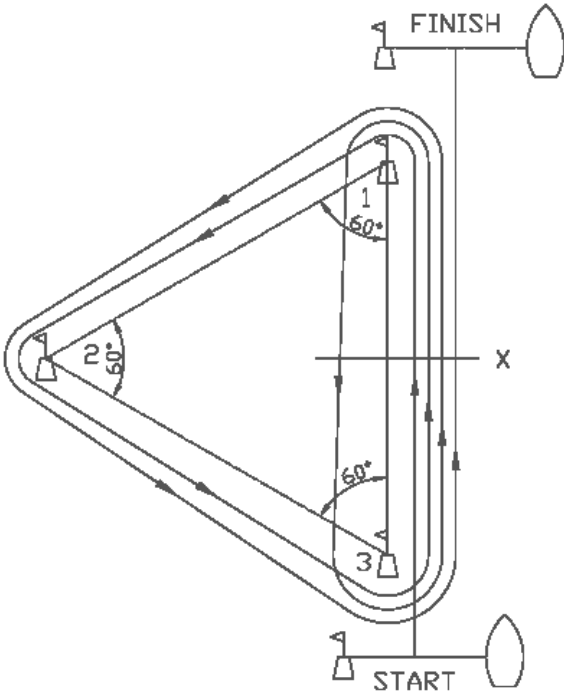

FIGURE 2



Start – 1 – 2 – 3 – 1 – 3 – 1 – 2 – 3 – Finish

X = alternate start and finish position for back-to-back races