

**NS14 ASSOCIATION  
OF AUSTRALIA**

**CONSTITUTION**

**AND**

**CLASS RULES**

**JANUARY 2011**

# CONSTITUTION OF THE NS14 ASSOCIATION OF AUSTRALIA

## CONTENTS

|  |    |
|--|----|
| PART 1.....  | 2  |
| 1. INTRODUCTION.....   | 2  |
| 2. GENERAL.....  | 2  |
| 3. MEMBERSHIP.....   | 3  |
| 4. GOVERNANCE.....   | 3  |
| 5. NATIONAL COUNCIL – COMPOSITION, APPOINTMENT AND AUTHORITY.... | 3  |
| 6. NATIONAL COUNCIL – MEETINGS AND AGENDA.....                   | 3  |
| 7. NATIONAL EXECUTIVE – ROLE AND COMPOSITION.....                | 4  |
| 8. NATIONAL EXECUTIVE – MEETINGS AND AGENDA.....                 | 5  |
| 9. AMENDMENT OF THE CONSTITUTION.....                            | 5  |
| 10. INDEMNITY.....   | 6  |
| PART 2.....  | 7  |
| 11. CLASS RULES.....   | 7  |
| SAFETY REQUIREMENTS.....   | 12 |
| APPROVED MATERIALS AND THEIR USAGE.....                          | 13 |
| MEASUREMENT FORM.....  | 14 |
| SAIL MEASUREMENT FORM.....                                       | 15 |

### Notes

The Constitution is published in two parts. Part 1 addresses governance and administrative matters and includes Sections 1 to 10. Part 2 consists of Section 11 - the Class Rules.

Wherever possible, the terminology used in the Constitution is gender neutral – where in the interests of clarity of expression traditional terms such as Chairman are used, they are so used on the basis of implied applicability to both male and female.

## PART 1

### 1. INTRODUCTION

- 1.1. The NS14 is a development class sailing dinghy controlled by Class Rules intended to result in boats which combine both close racing and acceptably high performance, but without demanding athletic or acrobatic ability. The boats should appeal to crews who are not attracted to large-sail-area or trapeze classes. As a secondary intention the boats should be reasonably suitable for family use and for training, and should be easily handled by two adults both on and off the water. The boats should have reasonable stability and should be safe, reasonably comfortable, inexpensive and durable.

### 2. GENERAL

- 2.1. The Association shall be known as the NS14 Association of Australia.
- 2.2. The Association is an association of NS14 State and Territory Associations, hereafter referred to as State Associations.
- 2.3. The Association shall be financed by contributions from the State Associations as determined by the National Council.
- 2.4. The purpose of the Association is to control the affairs of the NS14 Class in Australia.
- 2.5. The objectives of the Association are:
- to govern, organise and administer the affairs of the NS14 Class,
  - to promote the NS14 Class and foster NS14 sailing activities across Australia,
  - to sponsor the National Championships of the NS14 Class, and

- d. to co-ordinate the activities of NS14 State Associations.
- 2.6. The Association shall meet these objectives by encouraging the formation of State Associations.
- 2.7. State Associations shall be delegated responsibility for the control and promotion of the NS14 Class within respective States. State Associations shall represent the NS14 Class in all dealings with the Yachting Associations or Councils of the respective States.
- 2.8. The Class Flag shall be a white Class Insignia on a sky-blue field.
- 2.9. The financial year of the Association is 1<sup>st</sup> September to 31<sup>st</sup> August.

### **3. MEMBERSHIP**

- 3.1. Membership of the Association is limited to State Associations whose constitutions are compatible with the Constitution of the Association and who have adopted without amendment, the Class Rules listed in Part 2 of the Constitution.
- 3.2. Membership of the Association shall be conditional upon payment of the contributions prescribed by the National Council.
- 3.3. State Associations shall pay an annual contribution for each of their individual members, not being life members.
- 3.4. The annual contribution from State Associations shall be payable by 31st October each year. A State Association that has not paid its annual contribution by the due date shall forfeit its seat on the National Council and forfeit its Representative on the National Executive until the annual contribution is paid.
- 3.5. The annual contribution for each State Association shall also be used to calculate the voting strength of State Associations as prescribed in Section 9.6.
- 3.6. State Associations may make additional payments to their annual contribution at any time after 31st October, as a consequence of recruiting new members. The increased annual contribution shall be used to calculate amended voting strengths of State Associations as prescribed in Section 9.6.

### **4. GOVERNANCE**

- 4.1. The Association shall be governed by a National Council and administered by a National Executive subject to the authority of the National Council.
- 4.2. The National Council shall formulate Association policy and the National Executive shall implement Policy.
- 4.3. The National Council shall be chaired by the elected National President who also shall be Chair of the National Executive.
- 4.4. The National Council is the only authority through which change to the Constitution of the Association, including the Class Rules, can be effected.

### **5. NATIONAL COUNCIL – COMPOSITION, APPOINTMENT AND AUTHORITY**

- 5.1. The National Council shall consist of the Presidents of the State Associations or their endorsed delegates, one of which shall be elected National President by the members of the National Council.
- 5.2. Where a State President endorses a delegate to represent the State Association on the National Council, the delegate shall be a financial member of the State Association represented.
- 5.3. The National President shall chair the National Council and shall be elected from nominations put forward by State Associations. The National President shall be a financial member of a State Association.
- 5.4. Each State Association may nominate one candidate for the National President. Each State Association has one vote and the candidate who achieves the most Council votes shall be elected National President. In the event of a deadlock, the State President/delegate of the State Association that has the highest annual contributions shall have a casting vote.
- 5.5. The National President shall call for nominations for the appointment of the next National President by 31<sup>st</sup> May each year. The National President shall conduct a ballot for the election of National President before the 30<sup>th</sup> June each year.
- 5.6. The National President shall not serve for more than two consecutive years after which two years must pass before that person can be re-nominated for further appointment
- 5.7. The National Council shall have complete authority in the management of the Association and in the administration of its funds, subject to the provisions of the Constitution.
- 5.8. The National Council shall have the authority to change the Constitution including the Class Rules, subject to the provisions of the Constitution.

### **6. NATIONAL COUNCIL – MEETINGS AND AGENDA**

- 6.1. The National Council shall meet at least once each year.

- 6.2. The National Council shall conduct an Annual Council Meeting after 31st October, and about the time and near the location of the National Championships.
- 6.3. Additional meetings may be convened in accordance with the provisions of the Constitution.
- 6.4. Meetings of the National Council including the Annual Council Meeting shall be convened by the National President.
- 6.5. The National President shall promulgate in writing, a notice of meeting and an agenda a minimum of 21 days in advance of the meeting. The National Council shall not vote on any matter that has not been listed in the agenda.
- 6.6. Meetings of the National Council shall be conducted in person or through some appropriate communication medium such as teleconferencing.
- 6.7. A National Council meeting requires a quorum of 51% of the number of Council members.
- 6.8. Each Council member shall have one vote and motions shall be carried by a majority of votes eligible to be cast (that is to achieve greater than 50% of the financial State Association Council members, both present and absent). Absent Council members may submit a proxy vote through the National President. In the case of deadlock, the National President shall declare the motion lost.
- 6.9. Voting should normally occur at the meeting, but the National President may defer voting for up to 60 days to allow Council members to seek guidance from their respective State Associations.
- 6.10. Where voting on a motion is deferred, the National President shall within 14 days promulgate the motion in writing to all State Associations, irrespective of whether their delegate was in attendance at the meeting. The National President shall declare the motion lost unless within 60 days of the meeting, a majority of votes eligible to be cast is received.
- 6.11. In the event of the National President being unable to attend a National Council meeting, the Council shall appoint a Council member as acting chair; that member shall retain their voting rights.
- 6.12. The National President may invite the Secretary/Treasurer of the National Executive to National Council meetings for the purposes of recording the minutes of the meeting and for presenting the financial position. The National Secretary/Treasurer shall have no vote.
- 6.13. The National President may invite officers of State Associations to attend National Council meetings. Invited members shall have no vote.
- 6.14. The Agenda for the Annual Council Meeting shall include:
  - a. confirmation of National Council representation by each State President or delegate,
  - b. confirmation by the National Registrar that each State Association is financial and of the number of financial members (excluding life members) in each State Association,
  - c. acceptance of the Annual Financial Statements for the preceding year,
  - d. acceptance of the Annual Registrar's Report detailing the number of boats registered at 30th June,
  - e. acceptance of reports from each State Association,
  - f. approval of an Annual Budget to cover the anticipated operating expenses of the National Executive for the coming year,
  - g. determination of arrangements for the National Championships two years hence,
  - h. confirmation of the appointment of an Auditor,
  - i. and business as listed in the agenda, including matters forwarded by State Associations or by the National Executive.

## **7. NATIONAL EXECUTIVE – ROLE AND COMPOSITION**

- 7.1. The National Executive shall implement policy and manage the day-to-day affairs of the Association subject to the provisions of the Constitution.
- 7.2. The National Executive shall consist of:
  - a) National President, who also chairs the National Council;
  - b) National Secretary/Treasurer -appointed by the National President;
  - c) National Registrar -elected at the first National Executive meeting for the year from nominations received by the National President;
  - d) National Measurer -elected at the first National Executive meeting for the year from nominations received by the National President;
  - e) NS14 Publicity Officer -elected at the first National Executive meeting for the year from nominations received by the National President; and
  - f) one Representative nominated by each State Association; such nominee may already be an officer of the National Executive;
  - g) NS14 Webmaster -elected at the first National Executive meeting for the year from nominations received by the National President.
- 7.3. All members of the National Executive must be financial members of a State Association.
- 7.4. The National Executive shall:
  - a) meet regularly to manage the affairs of the Association,

- b) authorise the expenditure of funds in accordance with the Annual Budget approved by the National Council,
- c) assist the National Measurer to achieve uniformity in measurement of boats by consistent interpretation of the Class Rules,
- d) foster a spirit of close racing within the intention of the NS14 Class,
- e) ensure all racing is conducted under the Rules of the ISAF, the Provisions of the AYF, the Regulations of the relevant State Yachting Authority and the Class Rules,
- f) represent the NS14 Class at the Australian Yachting Federation,
- g) arrange the National Championships of the NS14 Class, and co-ordinate the conduct of the Championships with the host State Association or Club or Sailing Authority, and
- h) arrange for the publication of material to promote the class, particularly through the NS14 website.

## **8. NATIONAL EXECUTIVE – MEETINGS AND AGENDA**

- 8.1. Meetings of the National Executive shall be convened by the National President who shall provide a minimum of seven days notice of meeting. An agenda shall be provided at least three days prior to the meeting.
- 8.2. Meetings of the National Executive shall be conducted in person or through some appropriate communication medium such as teleconferencing.
- 8.3. A National Executive meeting requires a quorum of 51% of its membership.
- 8.4. Each National Executive member shall have one vote. Where a National Executive officer is also the nominated Representative of a State Association, that individual shall exercise two votes – one for each National Executive appointment held.
- 8.5. National Executive motions shall be carried if they achieve greater than 50% of the sum of votes present and submitted by proxy (that is, if four votes are present and three are submitted by proxy, then four votes are required to carry the motion). In the case of deadlock, the National President shall have a casting vote.
- 8.6. The Secretary/Treasurer shall maintain the records, conduct the ballots and disseminate information to the National Council, National Executive and State Associations. The Secretary/Treasurer shall have charge of the funds of the Association and shall make such disbursements as the National Executive shall direct. The Secretary/Treasurer shall report the financial affairs of the Association by presenting an Annual Financial Statement to the President of the National Council by 1<sup>st</sup> November of each year. The Secretary/Treasurer shall report the number of individual members in each State Association (excluding life members) to the President of the National Council by 1st November each year.
- 8.7. The National Registrar shall maintain the Class Register of all measured boats; issue sail numbers, registration plates, certificates and transfer certificates as required by the Class Rules; report on the number of registered boats in each State Association at 30th June by presenting an Annual Registrar's Report to the President of the National Council by 1st November each year.
- 8.8. The National Measurer shall monitor and oversight the practice of class measurement; ensure consistent interpretation of Class Rules; maintain a record of interpretations of the Class Rules; advise State Associations on the procedure for effecting change to the Class Rules; and advise the National Executive on how to progress proposals for change to the Class Rules.
- 8.9. The NS14 Bulletin Editor shall coordinate and oversee the production of the NS14 Bulletin.
- 8.10. Subject to the approval of the National Council, the National President shall appoint annually an Auditor who shall certify the Annual Financial Statements for the Association.

## **9. AMENDMENT OF THE CONSTITUTION**

- 9.1. Amendment of the Constitution can only be initiated by a State Association. State Associations shall forward proposed Constitutional Amendments to the National President.
- 9.2. The National President shall within 30 days of receipt of a proposed Constitutional Amendment, promulgate the Amendment to all State Associations.
- 9.3. The National President shall convene, no earlier than two months after promulgation and no later than four months after promulgation, a Special National Council Meeting to vote on the proposed Constitutional Amendment.
- 9.4. The National President may conduct the Special National Council Meeting by either personal attendance, by some appropriate communication means, or by ballot. If conducted by personal attendance, the National President should encourage the submission of proxy votes by Council members unable to attend.
- 9.5. At the Special National Council Meeting, the voting power of each State Association shall be determined by the number of members aged 18 years or more (excluding life members, associate members and junior members) in each State Association, as determined by the level of the annual contribution paid by respective State Associations.

9.6. At the Special National Council Meeting the voting power of each State Association shall be:

|           |   |       |
|-----------|---|-------|
| <10 =     | 1 | vote  |
| 11-30 =   | 2 | votes |
| 31-50 =   | 3 | votes |
| 51-70 =   | 4 | votes |
| 71-100 =  | 5 | votes |
| 101-150 = | 6 | votes |
| 151-200 = | 7 | votes |
| >201 =    | 8 | votes |

9.7. The Amendment shall be carried if it achieves at least a 2/3rds majority of votes eligible to be cast (that is, the number of votes that is equal to or greater than 66.67% of the total voting power of all State Associations who have paid their annual contributions).

## **10. INDEMNITY**

10.1. The members of the National Council and of the National Executive of the Association and each and every one of them acting in relation to any of the affairs of the Association shall be indemnified out of the funds of the Association from and against all actions, costs, losses, damages and expenses which they or any of them shall or may incur or sustain by reason of any act done concurred in or omitted in or about the discharge of their duty or supposed duty in their respective offices, except such, if any, as they shall incur or sustain by or through their own wilful default or dishonesty and none of them shall be answerable for the acts or default of the other or others of them or for joining in any receipt for conformity or for any bankers or other persons with whom any moneys or effects belonging to the Association shall or may be lodged or deposited, or for the insufficiency or deficiency of any security upon which any moneys or effects of or belonging to the Association shall be placed out or invested or for any loss, misfortune or damage which may happen in the execution of their respective offices or in relation thereto except the same shall happen by or through their own wilful default or dishonesty.

## **PART 2**

### ***NS14 Association Class Rules***

#### **INTENTION**

The Class Rules are intended to result in boats which yield close racing with acceptably high performance, without demanding athletic or acrobatic ability. The boats should appeal to crews (such as husband and wife) who are not attracted to existing large sail area classes. As a secondary intention the boats should be easily handled by two adults both in the water and out and have stability and sail area such that trapezes are not required. Thirdly they shall be safe, reasonably comfortable, inexpensive and durable.

#### **11. CLASS RULES**

The NS14 is a development class sailing dinghy.

A Boat shall include, in their entirety, all its components as ready to race.

Before a boat can compete in a race as an NS14, the boat shall be registered and comply with the Class Rules as published from time to time.

The Class Rules presented in this section constitute the sole reference for the measurement of boats in this class.

The units of measurement shall be metric.

The NS14 is a development class and these rules may not cover every eventuality.

Rules to provide class restrictions are not to be interpreted to mean that any other item or part not mentioned is unrestricted. In cases where doubt exists, account should be taken of the intentions of the class and the matter should be referred to the National Measurer.

The acceptance and continued registration of a boat as an NS14 shall be at the ultimate discretion of the Executive Committee.

These rules apply to all new boats measured after 8<sup>th</sup> December 2002. New boats measured up to 8<sup>th</sup> December 2004, may also be measured to the previous (2000) Class Rules. As well as these provisions, any boat that could have been measured and passed as an NS14 at the time of its construction but for whatever reason was not measured as an NS14, may in the future be allowed to be measured to the NS14 Class Rules that applied at the time of its construction. Unless otherwise decided by the National Executive, a boat holding a valid measurement certificate to any previous version of the class rules dated prior to 8<sup>th</sup> December 2002, shall continue to be recognized as an NS14. If any part of the boat below the gunwale assembly is or has been modified, then the boat shall be remeasured to the current rules in their entirety and a new measurement certificate issued.

The Class Measurement Form is part of these rules. State Measurers must forward all Measurement Forms to the National Measurer.

##### **11.1. QUALITY**

11.1.1. Boats shall be in all respects sound, safe and seaworthy in design and construction. This includes the correct fixing of fittings and their purpose.

11.1.2. Where an innovation, for example in design or materials, makes it difficult to determine whether the requirements stated in these rules are met, a provisional measurement certificate will be issued by the State Measurer for a period, such period to be at the state measurers discretion. The State Measurer shall inform the National Measurer of the issue of the provisional certificate and details of the certificate. The National Measurer shall determine if the requirements of these rules have been complied with and if so authorise the issue of a measurement certificate. The National Measurer may revoke a measurement certificate issued by a State Measurer if he finds any part of the boat is constructed in such a way, or from such materials so as not to comply with the Class Rules and/or class intentions.

11.1.3. Materials: Unusually expensive materials or equipment shall be deemed to be contrary to the intention of the class and may be prohibited in the construction of hull, spars, sails, rigging, centreboard, rudder, fittings and/or components unless prior approval has been granted in writing, from the National Measurer, to use such construction or materials. **CHANGES TO THE APPROVED EXOTIC MATERIALS AND THEIR USAGE SHALL BE REVIEWED BY THE EXECUTIVE COMMITTEE ANNUALLY AND PUBLISHED FROM TIME TO TIME.** Any boat found to contain material/s contrary to those approved shall have its measurement certificate revoked.

## 11.2. TYPE OF BOAT

- 11.2.1. Hulls shall be of a conventional dinghy type. In any cross section of the hull, no horizontal or vertical line shall touch the hull skin more than once either side of the centreline. This excludes a gunwale assembly of normal dimensions. Scow, tunnel, catamaran and sailboard type hull forms are therefore not permitted.

## 11.3. HULL DIMENSIONS

- 11.3.1. Unless specifically required otherwise hereunder, all measurements shall be taken parallel to one of the three major axes of the hull vertical, longitudinal or transverse related to the waterline and fore and aft centre line of the hull. For most boats it is sufficient to estimate the waterline, which runs from near the base of the stem to the base of the transom. In case of doubt, the measurer may require the waterline to be found with the boat afloat and a crew weight of 130kg positioned as for sailing to windward.

### 11.3.2. Hull Length.

The overall length, including fittings and gunwale assembly, but not including rudder pintles, shall be between 4.25m and 4.30m as measured between perpendiculars fore and aft with the waterline horizontal. Rudder extensions are not allowed. To prevent their being fitted, any rudder fitting fixed to the boat and extending more than 50mm aft of the normal aft length measurement is to be included in the overall length. Additions to the rudder box or rudder, which artificially extend the overall length of the hull, are prohibited.

### 11.3.3. Hull Beam.

The beam of the hull including fittings and gunwale assembly, at its widest points shall be between 1.60m and 1.83m. The beam when measured at 2.50m aft from the fore perpendicular (as used in taking the measurement in rule 11.3.1) and 200mm above the bottom of the centreline of the hull, with the boat upright, shall not be less than 1.22m.

### 11.3.4. Hull Depth.

The depth 2.50m from the fore perpendicular (as used in taking the measurement in 11.3.1 and 11.3.2) measured between the bottom of the centreline of the hull and the highest point of the gunwale or deck at the 2.50m station shall be not less than 450mm. In addition the boat, including all fixed fittings, but excluding a fixed mast pin, when upright shall pass between two parallel horizontal lines 660mm apart. (Fixed fittings do not include components removable with tools carried in the boat.)

### 11.3.5. Sectional Hollows.

A taut tape containing any vertical transverse section of the hull including the gunwale assembly shall not pass more than 60mm from the hull skin, measured at right angles to the tape. Additionally, a taut tape containing the vertical transverse section of the hull below the 2.50m measurement point defined in 11.3.2 shall show no separation from the hull.

## 11.4. HULL WEIGHT

- 11.4.1. The minimum weight of the dry hull with permanent fittings attached, but without spars, centreboard, rudder and rudder box, sails, standing and running rigging, shall be 64.0kg. Any corrective weight necessary shall be permanently fixed not less than 300mm above the keel. Maximum weight of correctors shall be 5.0kg. Any artificial attempts to increase hull weight by the addition of nonstructural, localised material will result in measurement being refused. If subsequent remeasurement by a recognised Club Measurer shows the weight of the hull has changed and the State Measurer has been notified, the corrective weight may be reduced or removed accordingly and the revised weight recorded on the measurement form.

### 11.4.2. Permanent fittings include:

- a) Tow Ring
- b) Jib fairleads
- c) Sidestay cars
- d) Mainsheet blocks
- e) Mainsail traveller and pulleys
- f) Nonremovable compass, mounting or base (as noted on measurement form)
- g) Barber hauler for jib sheets
- i) Control lines of not more than 6mm other than mainsheet and jibsheet
- j) Vang systems
- k) Hatches, hatch covers and transom flaps.

11.4.3. Permanent fittings do not include:

- a) rudder box and removable rudder pin
- b) paddle
- c) tow ropes
- d) bailing buckets
- e) mainsheet and jibsheet
- f) removable compass

11.5. BUOYANCY

11.5.1. Buoyancy tanks shall be watertight. Hatch covers if not of screw-in type shall be positively secured and fitted with watertight seals. A controlled leak, to equalise air pressure, is permissible but shall not exceed an area of 2mm<sup>2</sup> and shall be in a position which is not immersed with the boat either way up.

11.5.2. The hull shall contain a minimum of .45 cubic metres of buoyancy volume. This buoyancy shall be distributed in such a way within the hull as to enable the boat to be righted and sailed on after a capsize. If the measurer is uncertain this rule has been complied with he may require a demonstration of the capacity of the boat to be righted and sailed on in heavy weather.

11.5.3. The hull complete with rudder and centreboard but without the rig, shall provide buoyancy of at least 20kg so distributed that the boat will float upright with all buoyancy compartments flooded.

11.6. SAILS

11.6.1. The maximum sail area shall be 9.3 square metres, when measured according to 11.6.8. A boat shall set no more than one mainsail and one jib. The mainsail shall be deemed to be the sail with the majority of the sail area.

11.6.2. All sails must be capable of being stowed in sailbags of normal dimensions. For the purpose of this rule, 'long' sailbags for the stowing of rolled up sails are regarded as normal. Sails may be constructed from any approved material as published by the association.

11.6.3. All sails intended for use by a boat racing as an NS14 in accordance with the Class Rules shall be measured by a recognised Club Measurer. The measurer shall initial the sail and mark on it the measured area and the date of measurement in lettering not less than 20mm high. All sails must have a suitable area near the tack for this measurement to be written. A measurer may request a sail to be remeasured at any time at his discretion. The Club Measurer shall forward all measurement forms to his State Measurer.

11.6.4. Not more than one mainsail and two jibs may be registered for use by an NS14 racing at a National or State Association Event. Additional sails may be substituted, in the case of damage, at the discretion of the Race Committee conducting the Event.

11.6.5. The mainsail shall be raised on a halyard and shall be capable of being raised into or lowered from sailing position from within the boat with the boat afloat and upright.

11.6.6. The class insignia and the registration number of the boat shall be within plus or minus 10 percent of the dimensions shown in rule 11.10.7. These shall be of a colour which clearly contrasts with, in all light conditions including backlit, the colour of the sails. The class insignia on the starboard side shall be affixed nearer the top of the mainsail and that on the port side below it. The distance from the lower part of the class insignia to the upper part of the registration number is not to be less than 150mm. All sail numbers must be at least 50mm apart. No part of the class insignia and/or the registration number shall appear below a horizontal line 1.5m above the clew of the mainsail.

11.6.7. Class insignia and sail number must be on sail at time of measurement. Other than a sailmakers sign (not larger than 150mm x 150mm) no other signs, symbols or insignia are allowed on the sails.

11.6.8. Measurement Method The method used to measure sails shall measure surface area as distinct to projected area.

a) All measurements are overall and shall include bolt ropes, tabling etc.

b) The head of the sail is defined as the point on the Luff, or its extension, level with the highest point of the sail projected perpendicular to the Luff or its extension.

c) The clew of the sail is defined as the aftermost part of the sail projected to the foot or its extension, including foot rope, if any.

d) Sails can usually be measured by the method on the Class measurement form. All measurements are to be included. If any measurement is zero, this should be noted on the measurement form. If abnormal sails are developed which cannot be satisfactorily measured this way, a full description of the sails and the method used to measure them shall be submitted to the National Measurer. Any area which is of abnormal shape shall be divided and calculated as individual areas so as to determine the correct surface area.

e) Sails shall be taken off spars to be measured, and laid on a flat, hard surface, with the corners tied to suitable pegs.

f) The sail luff shall be pulled taut with sufficient tension and pegged to ensure removal of wrinkles across the line of the dimension taken.

g) The clew of the sail shall be tensioned and pegged so as to remove wrinkles across the lines of measurement and apply equal tension to the foot and leech.

h) The straight line measurements shown on the class measurement form shall be delineated by tying a string tightly around nails inserted in the flat surface at the corners of the sail. In the case of headboards or cutoff tacks, etc, the nails shall be inserted at the intersections of the luff and leech, etc., projected.

i) Any straight line measurement areas are to be calculated by the areas of the triangles. i.e. half times the length times the perpendicular height.

j) The areas of luffs, foots and roaches of normal shape and fair curve are to be calculated by multiplying the length by twothirds the maximum offset. The edges shall be pulled out by hand if necessary to make the sail lay flat while the roaches are being measured.

k) In the case of a sail with a deep curve, the fullness may be removed by a fold as shown at Nn on the Measurement Form. This dimension is one side of the fold and the area is  $4/3Nn$ .

l) When the two sides of the sail set separately as in double luff sails, both sides of the sail shall be measured and the total area counted. This excludes the normal pocket up the luff of a jib up to 50mm in width.

m) All measurements shall be made to the nearest millimetre. All area components shall be calculated to the nearest 0.001m<sup>2</sup>. The total area of the sail shall be quoted to the nearest 0.1m<sup>2</sup>. All rounding will be as per Australian Standard 2706 1984 to the number of decimal places as noted.

#### 11.7. SPARS

11.7.1. The mast may not extend more than 5650mm above the highest point of the deck including all fixed fittings, but excluding a mastpin. If the mast extends more than 5500mm above the highest point of the deck including all fixed fittings, but excluding a mastpin, the portion of the mast between 5500mm and 5520mm shall be painted a contrasting colour to the mast. No portion of any sail shall set above the bottom of this band.

11.7.2. Only one mast shall be registered for use by a boat racing as an NS14. The Club Measurer shall initial the mast and mark on it the hull number, measured length and the date of measurement in lettering not less than 20mm high. A measurer may request a mast to be remeasured at any time at his discretion. The Club Measurer shall forward all Measurement Forms to his State Measurer.

11.7.3. All spars, excluding fittings, shall pass through a ring of 100mm inner diameter. For the purpose of this rule, the mast track is not regarded as a fitting.

11.7.4. The clew of the jib may be boomed out or held on either side of the boat. A spar used for this purpose may be held in the hand or fixed anywhere to the hull, spars or rigging, and when stowed shall not overhang the boat at the bow or stern.

11.7.5. A bowsprit is not allowed.

11.7.6. If any spar, or other device, other than the mast, boom, jib boom or pole increases the sail area, then the amount by which it increases the sail area shall be measured as part of the sail area.

#### 11.8. THE CREW

11.8.1. The crew shall consist of two (2) or more persons.

11.8.2. At least one member of the crew must be a member of an NS14 Association.

#### 11.9. EQUIPMENT

11.9.1. Boats shall at all times comply with all the requirements of the Yachting Australia Safety Regulations as shall apply to the NS14 Class. Additional Safety requirements may also be included in the Class Rules.

11.9.2. Devices outside or extending outside the vertical projection of the gunwales may not be used to support or partially support a member of the crew outboard or partially outboard. Battened hiking pants above the knee will be deemed to comply with this rule.

11.9.3. No part of the boat or gear may project beyond the bow measurement station when the boat is sailing closehauled.

11.9.4. Only one centreboard and one rudder shall be registered for an association event.

- 11.9.5. Instruments other than watches and clocks, compasses and direct windreading indicators such as feathers are banned. Items such as boat speed & wind speed readouts and GPS are prohibited.
- 11.10. REGISTRATION
- 11.10.1. Before a boat can compete in a race as an NS14 it must be registered and measured. To register, the owner must join the NS14 Association of his state, or if his state has no Association, then another State. The Registrar must be notified of all changes to ownership, and a new certificate issued.
- 11.10.2. A registration number will be issued, on application by a member of an NS14 association who has acquired, or is in the process of acquiring, a boat which has not been previously measured as an NS14 and which the member intends to present for measurement as an NS14. The registration number shall apply to the hull and be displayed on the mainsail in accordance with rule 11.6.6. The association may set a fee for the issue of the registration number.
- 11.10.3. The Registrar will issue a Class Registration Certificate where a registration number has been previously issued and the boat is measured and is found to comply with the rules of the NS14 Class. The Registrar will issue a registration plate with the registration number of the hull engraved on it. Once issued, the owner shall fix this plate to the front of the cockpit in an easily visible place. The registrar must be notified of all changes to ownership, and a new certificate will be issued.
- 11.10.4. If any part of a boat is replaced, extensively damaged or modified, the owner shall have the replaced or modified item remeasured. (for the definition of 'a boat' see the General section at the beginning of these rules).
- 11.10.5. With the approval of the Executive Committee, the Registrar may withdraw a class registration certificate.
- 11.10.6. A boat name registered for an NS14 shall not be used by any other NS14 unless the name is qualified, in some way, such as by the addition of a numeral suffix.
- 11.10.7. Class Insignia

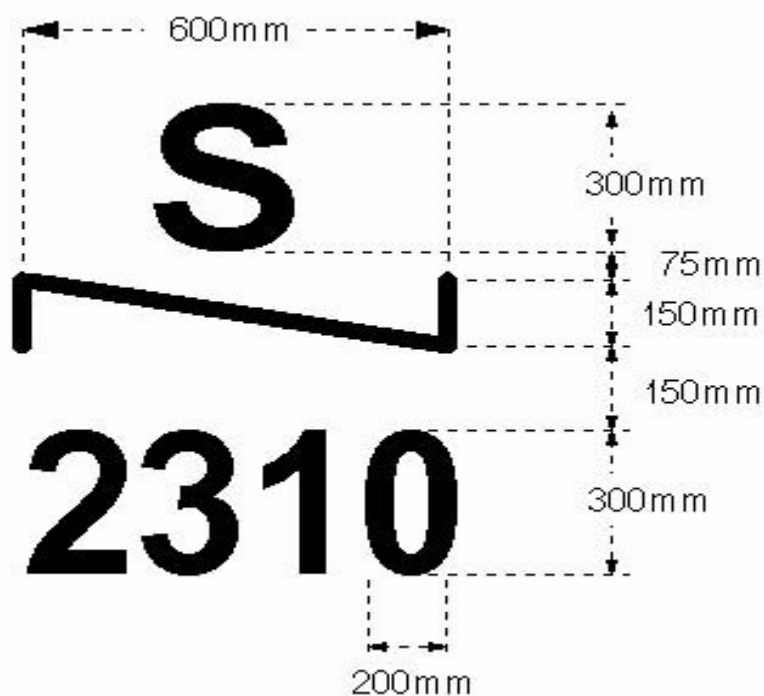

## SAFETY REQUIREMENTS

### TOWING LINE

A towing line not less than 11m long and 6mm in diameter. It shall be separate from the sheets and rigging and be readily accessible.

### TOWING RING

A towing ring of not less than 38mm internal diameter constructed of solid stainless steel not less than 4mm in thickness.

### SECURING OF CENTREBOARDS

Centreboards shall be secured to the hull by lanyard, bolt or pin such that they remain in the case when the hull is inverted.

### SECURING OF RUDDERS

Unless the rudder or rudder stock is securely fixed to the hull and requires tools to remove it, a rudder pin or pintle shall be drilled and fitted with a stainless retaining pin. Tillers and rudder blades if not permanently attached to rudder stocks shall be secured to them by pins or lashings while the yacht is on the water.

### MASTS

Hollow masts shall be either completely sealed or fitted with a drain hole not more than 300mm above the base of the mast and capable of emptying a mast full of water in 1 minute or less.

### BAILERS

All boats other than fully enclosed hulls or selfdrainers shall carry a bailer of not less than 2 litres capacity. This shall be attached to the hull by a light lanyard long enough to allow the bailer to be used without releasing it.

### PADDLES

All boats may carry a paddle with a minimum blade area of 400cm<sup>2</sup> and minimum handle length of 600mm.

### BUOYANCY VESTS

Each crew member shall wear, while racing, a buoyancy vest. These shall be approved Personal Flotation Devices (PFD) Type 1, 2 or 3.

### HULL IDENTIFICATION

The name of the boat, class number and club shall be placed on the hull externally on the transom or both sides near the transom in legible letters and figures. The name and class number shall be a minimum height of 50mm. The club name may be abbreviated to initials, e.g. NSC, KBSC, with a minimum height of 20mm.

In Victoria, the name of the club shall be in full but the words "Sailing Club" may be abbreviated to SC. The class name shall also be shown in letters 20mm high.

## APPROVED MATERIALS AND THEIR USAGE

If a material is not listed below, written permission must be granted by the National Measurer before it will be accepted.

### HULL

#### *Unlimited use:*

E-glass  
S-glass  
Polyester Resins  
Vinylester Resins  
Polyester Gelcoats  
PVC foam – e.g. as Klegcell, Divinycell, Corecell  
Core-mat  
Timber  
Glue – Epoxy (not for general glass laminating purposes)  
Aluminium, Brass or Stainless Steel plate

#### *Restricted use:*

Carbon-fibre – MAXIMUM TOTAL USAGE IN ENTIRE HULL – 0.2m<sup>2</sup> AREA

- May be used as an addition to normal glass layup in the construction of internal framing which is not part of the overall outer hull shell
- May be used for local reinforced areas
- Tube be used for a transom or other structural member

Kevlar – MAXIMUM TOTAL USAGE IN ENTIRE HULL – 0.2m<sup>2</sup> AREA

- May be used as an addition to normal glass layup in the construction of internal framing which is not part of the overall outer hull shell
- May be used for local reinforced areas

### SPARS

#### *Unlimited Use*

Aluminium  
Wood  
E-glass  
S-glass  
Polyester Resins  
Vinylester Resins  
Epoxy Resins/glue  
PVC Foam  
Composite Fibres

#### *Restricted Use*

### SAILS

All sailcloth shall have minimum weight of 2.5oz

### FOILS

As for hulls except carbon-fibre use is unlimited

### FITTINGS and RIGGING

Unless specifically disallowed by the National Measurer, any fitting which is commercially available and not retail cost more than 25% more than a comparable fitting is permitted

# MEASUREMENT FORM



## N.S. 14 ASSOCIATION

### CLASS MEASUREMENT FORM

CLASS NUMBER

OWNERS NAME

BOAT NAME

ADDRESS

DATE MEASURED

POSTCODE

PHONE NO.

*The complete rules of Part 2 (Class Rules) of the Association's Constitution and the accompanying Instructions to Measurers (2000) should be referred to when using this Measurement Form.*

IS THE OWNER A FINANCIAL MEMBER OF A N.S.14 ASSOCIATION? Note : Measurement cannot proceed if not.

#### 1. QUALITY

Is the boat sound, safe and seaworthy? \_\_\_\_\_

Centreboard Strength/Construction? \_\_\_\_\_

Construction materials : \_\_\_\_\_

#### 2. TYPE OF BOAT

Is the boat a conventional Dinghy-type? Description? \_\_\_\_\_

Design Name (if commercially available): \_\_\_\_\_

*Please attach drawings/photos if hull is a new design:* \_\_\_\_\_

#### 3. HULL DIMENSIONS

(a) Length (max overall 4.25-4.30m) \_\_\_\_\_

(d) Depth - 2.50m from bow min. 450mm) \_\_\_\_\_

(b) (i) Beam at widest point (1.60-1.83m) \_\_\_\_\_

-overall between horizontals (max. 660mm) \_\_\_\_\_

(ii) Beam 2.50m from bow 200mm \_\_\_\_\_

(e) Taut Tape - Overall (max. 60mm) \_\_\_\_\_

above keel (minimum 1.22m) \_\_\_\_\_

- Below Meas Pt (zero separation) \_\_\_\_\_

Yes / No \_\_\_\_\_

#### 4. HULL WEIGHT

Including Fixed fittings: \_\_\_\_\_

Comments (compass, etc.): \_\_\_\_\_

If underweight (min 64kg), have correctors been permanently fixed at least 300mm above keel? \_\_\_\_\_

Weight of correctors (max. 5kg): \_\_\_\_\_

#### 5. BUOYANCY

Approximate volume of Buoyancy? (min 0.45 cubic metre) (a) Tanks \_\_\_\_\_ (b) Emergency \_\_\_\_\_

Is distribution satisfactory? \_\_\_\_\_

#### 6. SAILS

(a) Have all sails been submitted for measurement? \_\_\_\_\_

(b) Brand of sails and construction materials: \_\_\_\_\_

(c) Total of Larger Jib and Mainsail (maximum area 9.3 square metres) \_\_\_\_\_

(d) Is mainsail capable of being hoisted into and lowered from sailing position while afloat? \_\_\_\_\_

(e) Have class insignia and number been affixed in the proper manner? \_\_\_\_\_

(f) Does owner understand that only one mainsail and two jibs may be registered? \_\_\_\_\_

(g) Have areas, dates and initials been marked on sails? \_\_\_\_\_

#### 7. SPARS

(a) Length \_\_\_\_\_ (Date, Sail no. and measured mast length also to be marked on mast) \_\_\_\_\_

Overall not more than 5.65m above the highest part of hull? \_\_\_\_\_

If more than 5.50m above highest point has max. height band been painted in position (5.50-5.52m)? \_\_\_\_\_

(b) Width and Depth. Will all spars pass through 100mm diameter ring? \_\_\_\_\_

(c) Is mast completely sealed? \_\_\_\_\_

(d) If not, is drain adequate? \_\_\_\_\_

(e) Brand and Construction materials: \_\_\_\_\_

Mast: \_\_\_\_\_

Boom: \_\_\_\_\_

Other: \_\_\_\_\_

#### 8. CENTREBOARD AND RUDDER

Are centerboard and rudder fixed so that they cannot detach accidentally? \_\_\_\_\_

#### 9. EQUIPMENT

(a) Are there external devices for leverage? \_\_\_\_\_

(b) Racing Equipment - Does boat comply with the current racing rules? \_\_\_\_\_

(c) Does the owner understand that only one mast, one centreboard and one rudder may be used? \_\_\_\_\_

#### MEASURERS COMMENTS

\_\_\_\_\_  
\_\_\_\_\_

Signed

CLUB MEASURER

Signed

ASSOCIATION MEASURER

# SAIL MEASUREMENT FORM

## NS14 Sail Measurement Form

Class Number

Owners Name

Boat Name

Address

Date Measured

Postcode

Phone No.

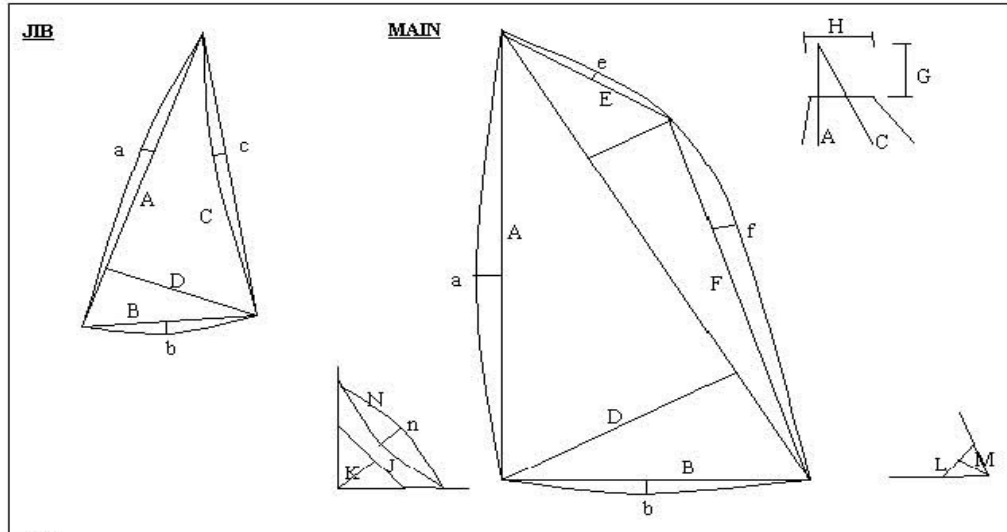

### JIB 1 - Brand & Construction Materials:

| Lengths (mm) |  |   |  | Areas   | Calculated | Reduced to 0.001         |
|--------------|--|---|--|---------|------------|--------------------------|
| A            |  | a |  | 1/2 AD  |            |                          |
| B            |  | b |  | 2/3 Aa  |            |                          |
| C            |  | c |  | 2/3 Bb  |            |                          |
| D            |  |   |  | 2/3 Cc  |            |                          |
|              |  |   |  | + Total |            |                          |
|              |  |   |  | - Total |            | Reduced total to 0.1sq m |
|              |  |   |  | TOTAL   |            |                          |

### JIB 2 - Brand & Construction Materials:

| Lengths (mm) |  |   |  | Areas   | Calculated | Reduced to 0.001         |
|--------------|--|---|--|---------|------------|--------------------------|
| A            |  | a |  | 1/2 AD  |            |                          |
| B            |  | b |  | 2/3 Aa  |            |                          |
| C            |  | c |  | 2/3 Bb  |            |                          |
| D            |  |   |  | 2/3 Cc  |            |                          |
|              |  |   |  | + Total |            |                          |
|              |  |   |  | - Total |            | Reduced total to 0.1sq m |
|              |  |   |  | TOTAL   |            |                          |

### MAINSAIL - Brand & Construction Materials:

| Lengths (mm) |  |   |  | Areas    | Calculated | Reduced to 0.001         |
|--------------|--|---|--|----------|------------|--------------------------|
| A            |  | a |  | 1/2 CD   |            |                          |
| B            |  | b |  | 1/2 Cc   |            |                          |
| C            |  | c |  | 2/3 Aa   |            |                          |
| D            |  | e |  | 2/3 Bb   |            |                          |
| E            |  | f |  | 2/3 Ee   |            |                          |
| F            |  | n |  | 2/3 Ff   |            |                          |
| G            |  |   |  | 4/3 Nn   |            |                          |
|              |  |   |  | + Total  |            |                          |
| J            |  |   |  | - 1/2 GH |            |                          |
| K            |  |   |  | -1/2 JK  |            |                          |
| L            |  |   |  | - 1/2 LM |            |                          |
|              |  |   |  | - Total  |            | Reduced total to 0.1sq m |
|              |  |   |  | TOTAL    |            |                          |

Comments and Calculations

TOTAL SAIL AREA MAIN & JIB